



## Model ZVH-50 Ventless Hood with Oven

### Ventless Exhaust Hood System with Two Deck Electric Oven

#### HOOD FEATURES

- Certified Ventless  
UL Certified Ventless under 710B
- Stainless Steel, Durable and polished 18-gauge
- Convenient  
Easily vent grease-laden vapors
- Self-contained, compact  
Eliminates need for ductwork or roof fans
- Meets food service requirements  
Triple filter system with updraft technology designed  
to trap grease particles, eliminate condensation,  
and reduce cooking odors
- Safe  
Optional built-in Ansul R-102 wet chemical fire  
suppression system (field installation must be performed  
by an ANSUL distributor)
- Alert System  
Color coded, lighted alerts to ensure system  
is running safely and efficiently
- Interlocking Start Safety Feature  
Does not allow hood and oven to work separately

#### WARRANTY

- One year limited manufacturer's warranty



SHOWN  
ZVH-50 Ventless Hood with Oven

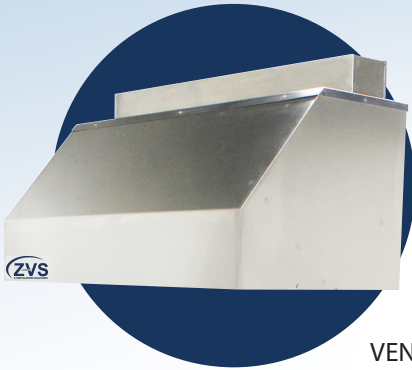

VENTLESS HOOD

**Important Ventless Information:**

- Clearance – Ventless clearance requirement above unit 18"
- 30" clearance at pull station. (Pull station located on left can be requested on right)

**MODEL ZVH-50 VENTLESS COMBO**

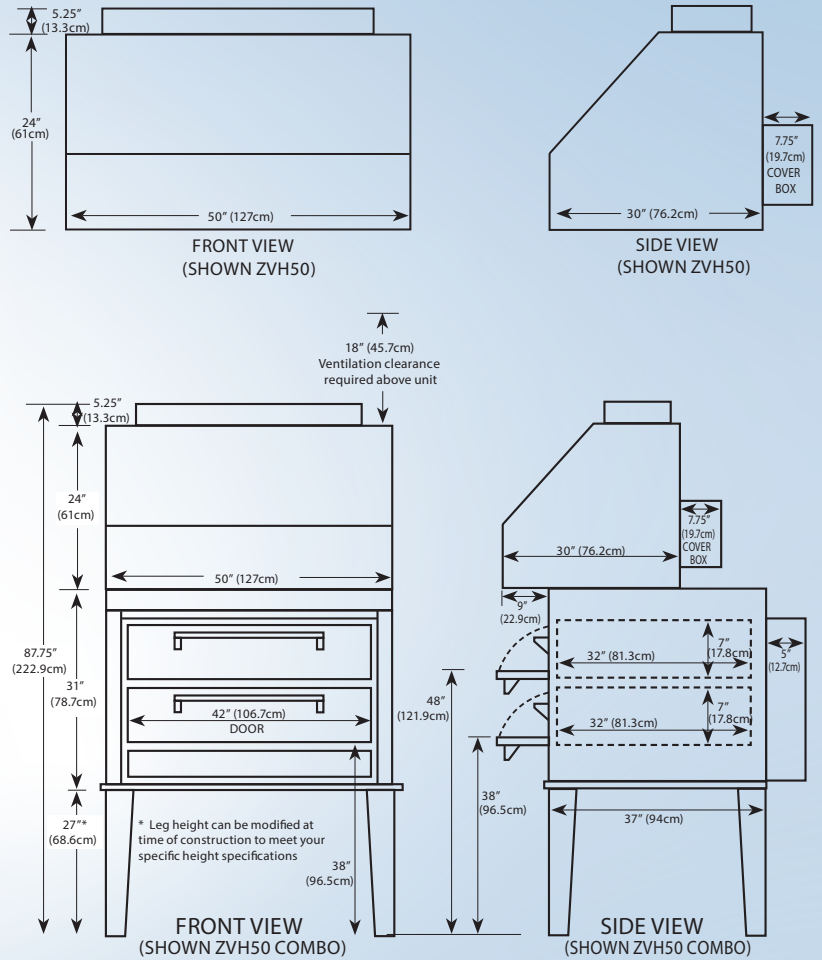

**VENTLESS HOOD**

|                              |  |
|------------------------------|--|
| Dimensions .....             | 50" (127cm) wide x 37.75" (95.9cm) deep x 29.25" (74.3cm) high |
| Ventilation Clearance .....  | 18" (45.7cm) from top of unit, not including damper            |
| Pull Station Clearance ..... | 30" (76.2cm)   |
| Shipping weight .....        | 325 lbs (147.4kg)  |
| Voltage .....                | 208/240 V AC, single or three phase                            |



655 DEARBORN PARK LN,  
 WORTHINGTON, OH 43085  
 TELEPHONE: 800-492-7400  
 EMAIL: QUOTING@Z-VENT.COM