

# THE CLEAR CHOICE IN GREASE DUCTS



## ZERO CLEARANCE GREASE DUCT AND INTEGRAL FIRE-RATED CHASE



- **3" & 4" Wall Thickness**
- **High Temperature Blanket Insulation**
- **5" to 36" I.D. Diameters**
- **Smaller Footprint with 3" Wall**
- **Lighter Weight**
- **2-Hour Fire Rating**
- **Limited Lifetime Warranty**



ZVS is the most innovative factory-built kitchen grease duct in the industry. With a zero clearance rating, our integrated chase construction sets the standard for design.

Available in both stainless and aluminized steel exteriors, ZVS can be customized to your unique application requirements. ZVS is the clear choice for new restaurant construction or retrofitting future expansions or modifications.



UL Listed per UL1978  
UL Classified per UL 2221  
IMC, UMC and NFPA96 Code Compliance



# ZERO CLEARANCE GREASE DUCT AND INTEGRAL FIRE-RATED CHASE

## INTEGRAL CHASE

No longer will architects or contractors need to design and install a fire-rated chase to provide protection as required for welded steel or other grease duct designs. The Z-Clear system helps reduce floor space requirements (fig. 1) and additional time and costs associated with constructing an on-site fire chase (fig. 2).

## SETTING THE STANDARD

ZVS meets the following stringent codes and standards:

### CERTIFICATIONS

Model	UL1978	UL2221	ASTM-E2336*
Z3/ZC	Yes	Yes: 2 Hr	Yes: 1 Hr
Z4/ZC+	Yes	Yes: 2 Hr	Yes: 2 Hr

\*ASTM E2336 is only code required for field applied grease duct enclosures (i.e. grease duct insulation wraps applied to field fabricated grease duct)

## PERFORMANCE

Energy efficiency and overall performance are greatly improved with round grease duct designs due to less flow resistance. In addition, round systems are much easier to clean and reduce the opportunity for grease accumulation in the corners, like rectangular systems, increasing the risk of fire.

## SIMPLICITY

Almost no slope is required on horizontal runs of Z-Clear. Carbon steel duct systems require a 1/4" drop per 1 foot of ducting for proper contaminant drainage. Example: A 40ft. horizontal run of AMPCO's Grease Duct would require 10 inch less headroom than a typical field fabricated system.

## DESIGN SERVICES

The modular concept of factory-built grease duct provides for maximum design flexibility and ease of installation. Just ask for ZVS when utilizing your design services engineer for a complete system layout. The AMPCO engineering staff provides design services for special product applications and for installations requiring complex routing or unusual manifold systems.



UL Listed per UL1978  
UL Classified per UL 2221  
IMC, UMC and NFPA96 Code Compliance

## Grease Duct "Footprint" – 24" I.D. ZVS vs. 12"x36" Fabricated Welded Steel

fig. 1

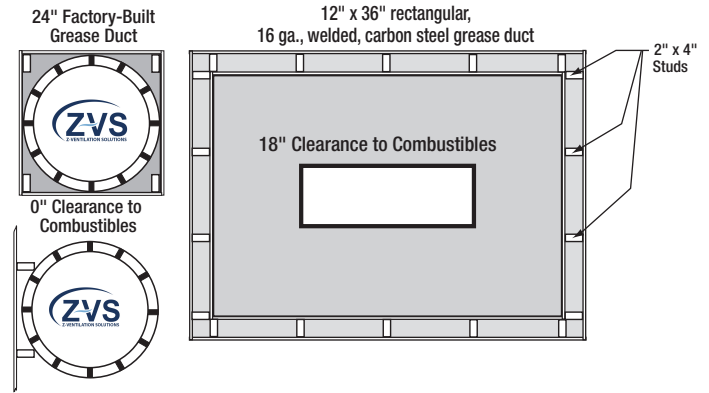
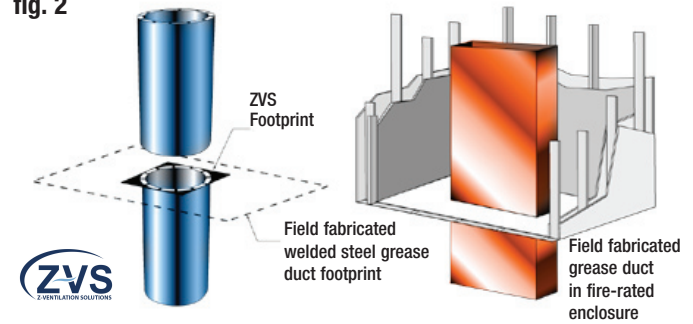

fig. 2



## Comparison of wrapped, welded steel and ZVS after 2000°F (simulated grease fire) for 30 minutes.



ZVS after 2000°F (simulated grease fire) for 30 minutes.

12" x 36" rectangular, 16 Ga., welded, carbon steel duct with generic "wrap" insulation – after 2000°F (simulated grease fire) for 30 minutes.

## THE CLEAR ADVANTAGE

- Better flow characteristics
- Prefabricated/modular design
- Superior safety and high temperature resistance
- Stainless steel maintains strength at much higher temperatures than carbon steel
- Cylindrical duct systems are far superior structurally compared to rectangular ducts
- Limited Lifetime Warranty

# ZVS Custom Venting Capabilities

---

## Decorative Outer Wall Options



- Painted colors – 180 standard RAL color options
- Alternate materials such as copper and polished stainless steel
- Laser-cut designs including patterns, logos, company names, and messaging

*Array of styling options customized to your unique interior or exterior application for an enhanced appearance – from matching a building facade to creating an inviting space that leaves a lasting impression.*

# ZVS Custom Venting Capabilities

---

Typical (unpainted) Aluminized Steel or Unpolished Stainless Steel

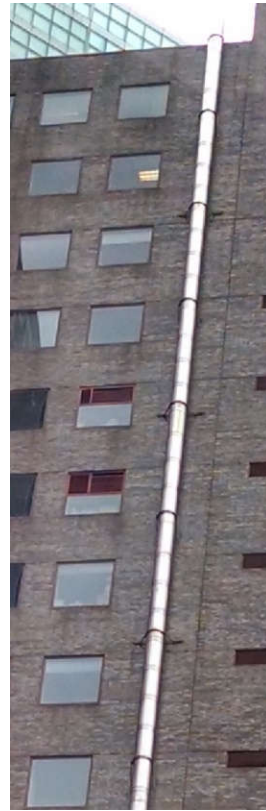

# ZVS Custom Venting Capabilities

---

## *Decorative Alternate Material and Factory-Painted Options*



**NYC Cathedral  
Copper Outer**



**High  
School  
Factory  
Painted  
Outer**



**Hospital**



# ZVS Custom Venting Capabilities

*Laser Cut Company Logos and Messaging*  
Pizza Oven Application



Company Logo

