



YOUR COMPLETE TURNKEY SOLUTION
For Foodservice Consultants, Architects and Design Dealers

Eliminate Pain Points with Z-Vent

How Z-Vent Ensures Success

Design & Drawings

- Detailed blueprints for proper air circulation and regulatory compliance.

BIM Coordination Meetings

- Digital modeling to identify conflicts and ensure seamless system integration.

Pre-Con Meetings

- Aligning all stakeholders on scope, timeline, and responsibilities before installation begins.

From Design & Planning

To Trades & Construction

To Execution & Compliance



Industry-Leading Warranty

Comprehensive Coverage for Your Ventilation Needs

Unmatched Protection – Z-Vent stands behind every system with the **best warranty term in the industry.**

What You Get:

- ✓ **Peace of mind** – Your investment is fully protected.
- ✓ **Unmatched durability** – Built to last, backed by our expert team.
- ✓ **Parts & labor coverage** – Ensuring peak performance when you need it most.

INDUSTRY-LEADING WARRANTY

2-Year

Parts Warranty

Covers defects in materials and workmanship for two full years from shipment.

1-Year

Labor Warranty

No labor costs for repairs or replacements in the first year.

New from Z-Ventilation Solutions

Z-Tech Demand Control System



Revolutionizing Energy Efficiency in Commercial Kitchens

- **Smart Motion & Heat Sensors** – Adjusts airflow in real-time based on cooking activity.
- **Energy Cost Savings** – Uses only the necessary energy, reducing utility expenses.
- **Quieter Kitchen Environment** – Minimizes ventilation noise for better communication and focus.
- **Seamless Integration & Customization** – Fits effortlessly into existing kitchen setups.
- **Expert Support** – Full-service consultation, installation, and ongoing support.

ZA Pro Series Hood



Efficiency & Cost Savings in One Versatile Solution

- **Seamless Integration** – Works effortlessly with Z-Tech demand control systems.
- **GEO-VARY Modular Grease Extractor** – Adjustable airflow for optimized efficiency.
- **Easy Installation & Configuration** – Supports wall-mounted and island setups.
- **Enhanced Ventilation** – Superior smoke, steam, and grease capture.
- **Operational Savings** – Cost-effective function with reduced capital investment.
- **Professional-Grade Design** – Suitable for any **Type I hood application**.

Introducing the Z-Scrub ESP Hood

The Latest Innovation in Commercial Kitchen Ventilation

Self-Contained Electrostatic Precipitator Hood

- Eliminates smoke and grease without traditional filters
- Uses Electrostatic Precipitation (ESP) technology to remove airborne contaminants
- Enhances air quality, reduces maintenance, and lowers fire risk

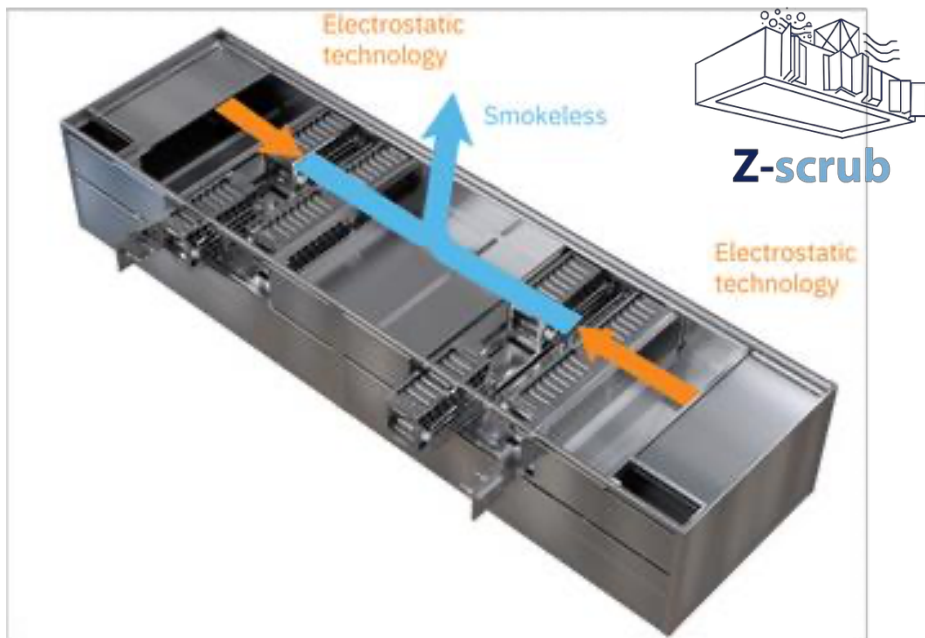

Key Benefits:

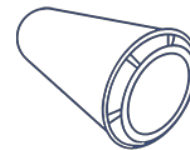
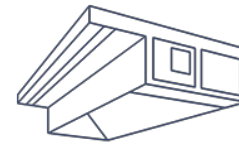

Cut Down on Cleanings & Save Money

- No more quarterly hood cleanings – only an annual inspection required
- Lower maintenance costs and improved operational efficiency

Reduce Fire Risk

- Prevents grease buildup in hoods and ductwork
- Minimizes fire hazards in commercial kitchens

Improve Air Quality

- Effectively removes smoke and grease from the exhaust system
- Keeps your kitchen cleaner, safer, and more efficient

Z-Ventilation Ventless Solutions

Eliminate the Need for Roof Fans, Ductwork, or External Venting

Why Go Ventless?

Ideal for historic buildings,
multi-story spaces, and
mobile operations

Quick installation &
immediate operation

Flexible, compliant, and
cost-effective



Ventless
Mobile
Hoods

- **Portable and flexible** – No fixed installation required
- **Perfect for food trucks** – Removes grease, smoke, and odors on the move
- **No external ductwork needed** – Maintain compliance anywhere



Ventless
Countertop
Exhaust

- **Compact tabletop unit** – Designed for small cafes and coffee shops
- Maintains air quality in tight spaces without major modifications
- Optimized for electric cooking equipment



Ventless
Pizza Deck
Oven Hood

- **Engineered for deck ovens** – Withstands high-heat pizza baking
- Ensures proper ventilation & safety compliance

Carmel Clay High Installation

When Carmel Clay High School needed a modern, efficient, and compliant kitchen ventilation system, ZVS delivered an end-to-end solution, ensuring optimal safety, performance, and compliance.

Key Project Highlights:

Professional Engineering Guidance

- Designed to meet local codes & safety standards
- Custom ventilation package for optimized performance

Customized Hood Package

- High-efficiency hoods tailored to the kitchen layout
 - **Key components installed:**
 - Centrifugal Downblast Exhaust Fan – Direct Drive
 - Modular Packaged Unit

Comprehensive Installation

- **Full System Install**– Exhaust & supply fans, ductwork, and controls
- Permit handling & start-up testing for full compliance

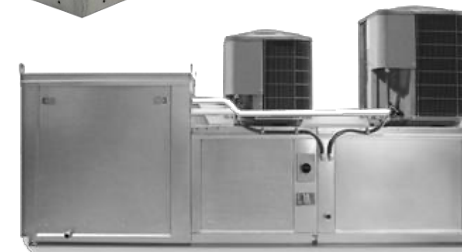
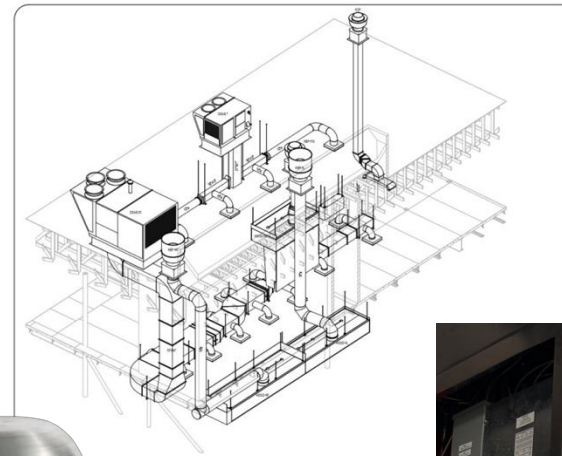

Z-VENT OVERVIEW

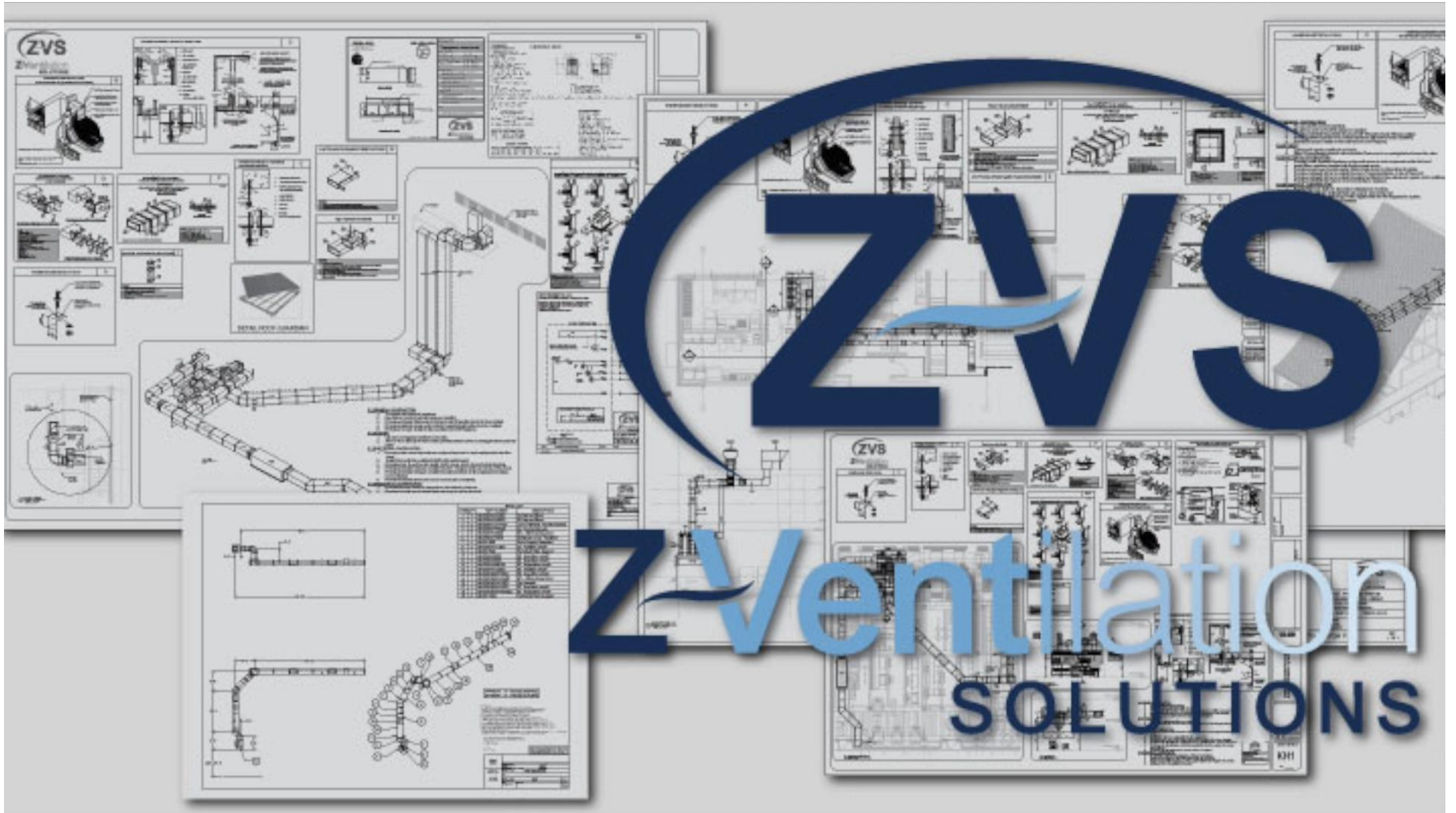

THE Z-VENT DIFFERENCE

TURNKEY

ZVS Creates a seamless process from the inception of a project through its final completion. Our team provides a single point of contact coordinating all aspects of a project from site survey, design, quoting, engineering, CAD/ Revit drawings, permitting, BIM and construction meetings, and installation through final test and balancing. This turnkey approach is a transfer of your risk to our team of experts.

EXPERIENCE

With years of field experience, we are easy to do business with. The combination of our Design, Engineering, and Multi-line Sales teams brings a level of knowledge far beyond the hood system. By focusing on all aspects of a project, above and below the hood our team can consult and add value to any aspect of your project from the rooftop down, making your life easier. ZVS's team of "In House" Mechanical Engineers are certified in 49 states.

FLEXIBILITY

Design flexibility. We offer multiple types of hoods, ducts, fans, controls, PCU's, fire suppression systems, and filters, This portfolio of products allows us to design projects based on performance, not product restrictions.

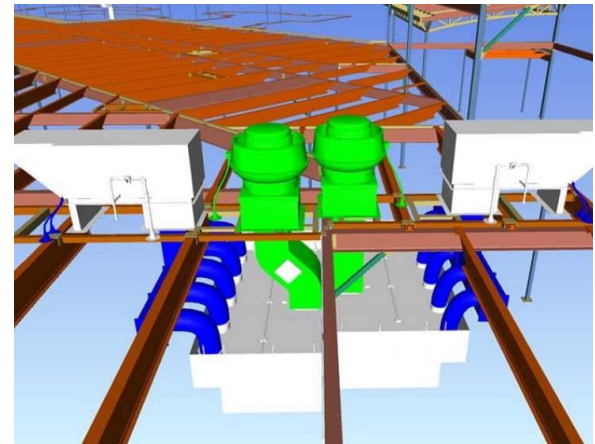

THE Z-VENT TEAM

TOTAL PROJECT ACCOUNTABILITY



Mike McGuire
Managing Partner
C 614.625.2895
mikem@z-vent.com



Brad Wallace
Senior Sales Engineer
C 609.876.7973
bwallace@z-vent.com



Brian Wilsker
Sales & Operations Engineer
317.654.4606
bwilsker@z-vent.com



Donnie Turley
Operations Manager
C 270.792.5257
dturley@z-vent.com



Jessica Tufano
Project Coordinator
D 229.425.6757
jtufano@z-vent.com



Alfonso Martinez
Inside Sales Engineer
D 412.265.7806
amartinez@z-vent.com



Lucie Cerna
Sales Coordinator
lcerna@z-vent.com



Nikki Hammers
Project Coordinator
D 270.935.9744
nhammers@z-vent.com

OUR PROVEN PROCESS



Site Survey

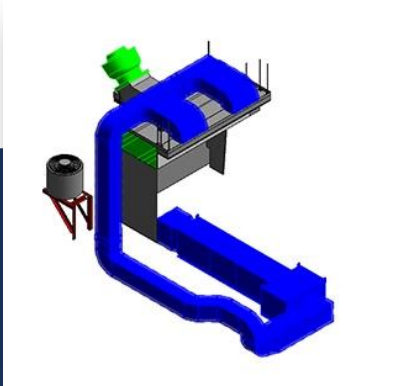

Design & Engineering



Quote



Installation

Exhaust			
Exhaust CFM:	Design = 1800	Actual = 1949	(108.3% of design)
Record the VFD HZ			Actual: 3
VOLTS			Actual: 2
HP	Design: 208		Actual: 0
HUB SET SCREW TIGHT	Design: 0.75		Actual: Y
FAN LEVEL	Design: Yes		Actual: Y
ROTATION	Design: Yes		Actual: C
FAN VIBRATION	Design: Correct		Actual: G
RPM - DESIGN	Design: Good		Actual: 1
RPM - MAX	Design: 1274		Actual: 1
RPM - MAX	Design: 1900		Actual: N
RPM - MAX RECOMMENDED	Design: 1600		Actual: N
FLA	Design: 2.6		Actual: 1
OVERLOAD SET POINT	Design: 2.6		Actual: 2
PHASE	Design: 3		Actual: 3
FAN WITHIN 5 MILES OF COAST			Actual: N
INSPECT ALL EXTERIOR SIDES OF UNIT, ANY VISIBLE DAMAGE	Design: No		Actual: N

Startup & Testing

COMPREHENSIVE DESIGN EXPERIENCE

PREMIER PROGRAMS

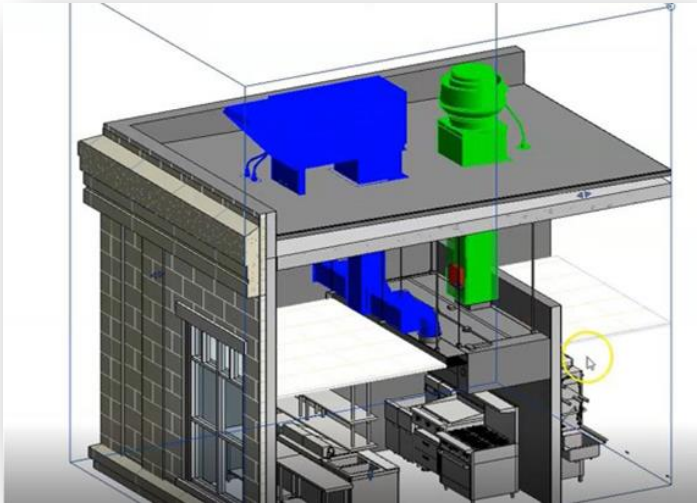

Hood System Modeled in Building Space

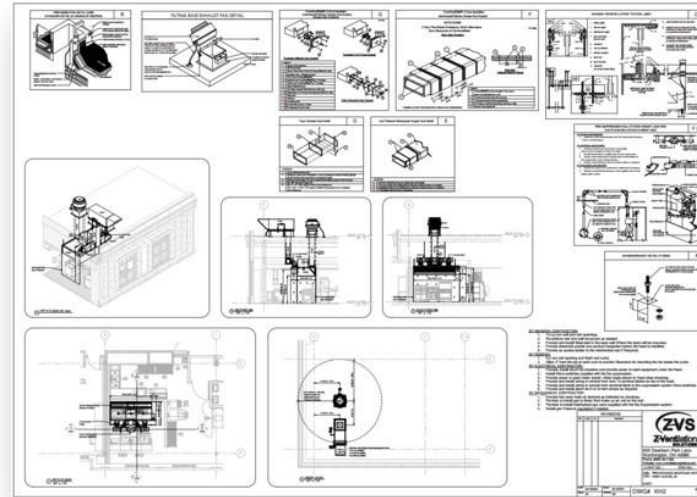

DWG & PDF Format drawings

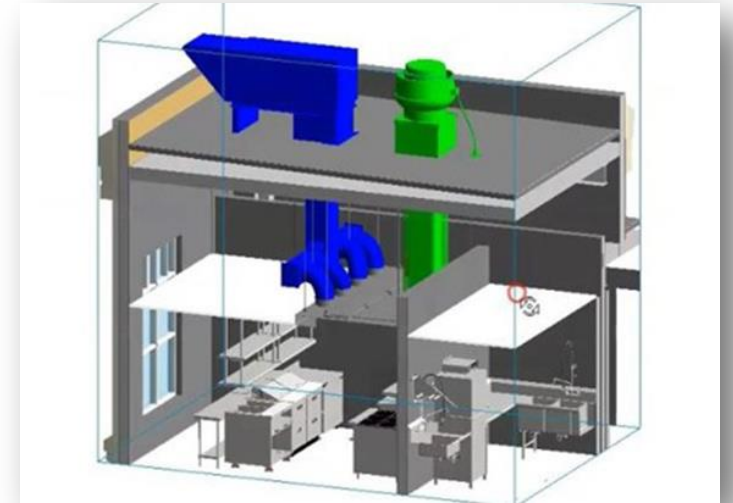

- Revit, NWC, BIM
- BIM Coordination meetings



PRODUCT PORTFOLIO

As a **PORTFOLIO** company, Z-Vent works with the best brands for **ALL** components of a hood.

We provide an **END-TO-END SOLUTION**, not just a product.

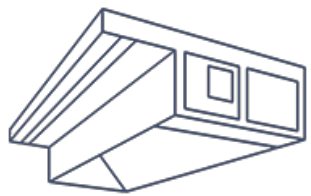

3 Hoods



2 PCU

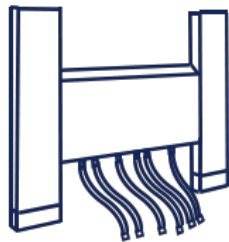

2 UDS



1 DOAS



3 Fans

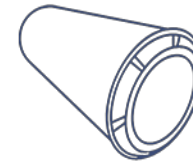

3 Ductwork

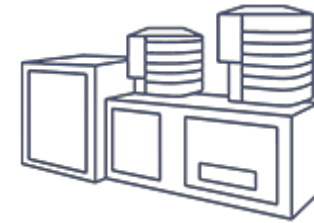



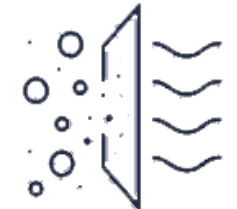





2 MUA



2 Purification

UNSURPASSED PRODUCT & SERVICE PORTFOLIO

COMPLETE LINE UP OF PRODUCTS & SERVICES

	Market		Equipment				Services			
	National Coverage of Rep. thru Food Service Dealer Channel	Consultant's Specified	Custom Hoods (Oval/Round/Special Finishes)	Low CFM Hoods	Full Line of Fan Package	Site Surveys	MEP Services in 50 States	Complete Hood System Design in building models	Installation Services	Start up
	X	X			X	X	X	X	X	X
	X	X	X	X						
	X	X			X	X			X	X
	X	X			X					X
									X	X
	X	X	X	X						
		X		X						X
		X		X						
	X	X	X	X						X

PRODUCT PORTFOLIO

HOODS – TYPE I AND TYPE II



- **ETL Listed:** For use over 450°F, 600°F, and 700°F surfaces.
- **Material:** 18-gauge type 304 stainless steel or aluminized steel.
- **Construction:** Liquid-tight welded exterior per NFPA-96.
- **Air Volume:** 600 – 1,400 cfm, ideal for various needs.
- **Low Ceiling:** Sloped canopy option for low ceilings.
- **Lighting:** U.L. Listed incandescent or LED lights, pre-wired.
- **Backshelf Option:** Close -proximity to cooking appliances.
- **High Exhaust Flow:** Superior ventilation efficiency.



- **High Exhaust Flow:** Efficient ventilation.
- **Quality Build:** Type 304/430 stainless steel.
- **Easy Install:** Pre-punched hanging angles.
- **Moisture Control:** 4-sided gutter and drain.
- **Fast Delivery:** Reduced lead times.
- **REM Option:** Removable baffles for condensation.
- **Lighting:** Incandescent, LED, fluorescent.
- **Make-Up Air:** Optional front/side plenums.
- **Enclosure Panels:** For a clean finish.

PRODUCT PORTFOLIO

MAKE UP AIR UNITS

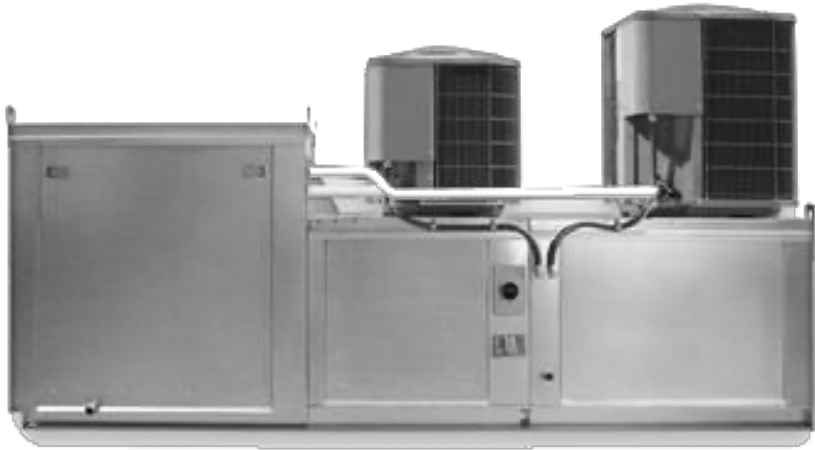

- **Direct Gas Fired:** 600 – 1,400 cfm, efficient heating.
- **Sensible Cooling + Efficient Heating:** Optimized for energy use.
- **Modulating Electric Heater:** For tempering make-up air.
- **Wide Air Volume:** 400 - 22,000 cfm, adaptable to needs.
- **High Static Pressure:** Up to 4" wg. for various applications.
- **Modular Packaged Unit:** AC & heating for 100% outdoor air.

PRODUCT PORTFOLIO

DOAS



Dedicated Outdoor Air System

- Danfoss variable speed inverter scroll compressor with VFD.
- Mixed air temperature/humidity sensor measures outdoor, return, mixed, discharge and space air.
- 2" metal mesh outdoor air filters.
- Low leakage outdoor air damper, includes integrated louver and bird screen assembly.
- Natural gas indirect fired furnace with constant 80% efficiency through modulation.
- Variable speed direct drive supply fan.
- Variable speed outdoor fans with EC motors, 10:1 turndown.



PRODUCT PORTFOLIO

EXHAUST FANS



- **Direct Drive Inline:** Air Volume up to 32,000 cfm.
- **High Static Pressure:** Up to 5" wg. for various needs.
- **Easy Access:** Two full-size access doors for maintenance.
- **General & Restaurant Duty:** Air Volume up to 28,000 cfm.
- **Versatile Use:** Suitable for general ventilation and restaurant duty.
- **Maximum SP:** Up to 6" wg., adaptable to different applications.
- **Industrial:** For high Static Pressure ie. Pollution Control Units

PRODUCT PORTFOLIO

PRE-FABRICATED DUCTWORK

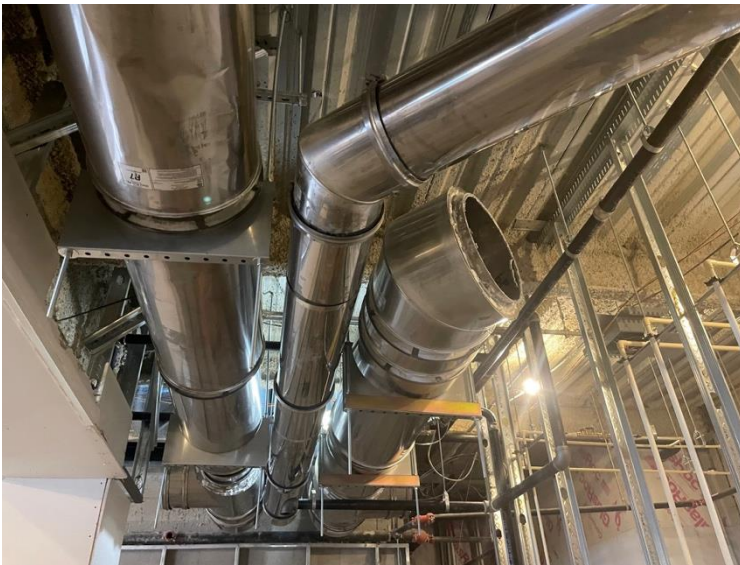

- ETL Listed.
- Factory-welded & dye tested for leaks.
- **Quick & easy installation** – no welding.
- Reduced & zero-inch clearance options.
- **Maximized Efficiency:** Ensures perfect air supply distribution.
- **Z-Clear Custom Finishes:** Aesthetic appeal for exposed ducts.
- **Prefabricated Double Wall:** Ideal for grease duct applications.
- **Innovative Design:** Factory-built for quality and efficiency.

NEW PRODUCTS

Z-SCRUB SERIES



Pollution Control Unit (PCU)

- Eliminates an expensive remote PCU.
- Reduces space.
- Saves time and money on installation.
- Easy to service.
- Scrubs the air at the hood prior to duct connections.
- Integrates with Building Management Systems.

Two sizes: ZST-40-T & ZST-20-T

Z-SCRUB OVERVIEW

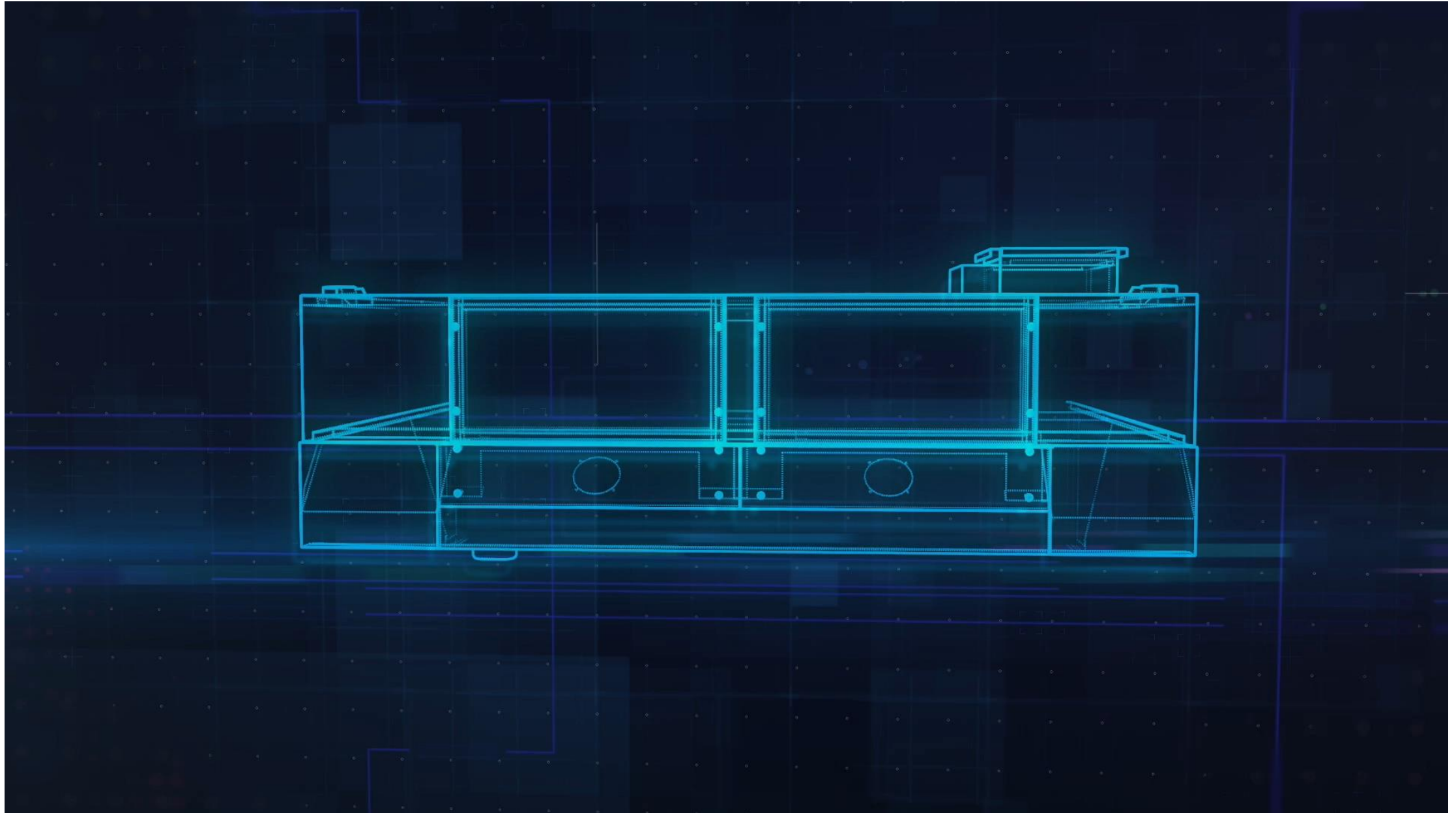

NEW PRODUCTS

S.M.A.R.T VENT



BAFFLES THE AIR - UP TO 80%

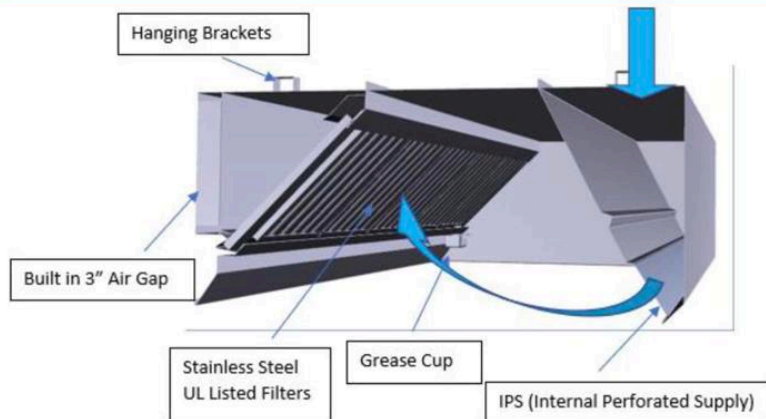

S.M.A.R.T Vent will **COST** you **LESS!**

**Sustainable
Makeup
Air
Return
Technology**

- Lower up-front costs
- Lower energy bills
- Up to 80% fresh air return

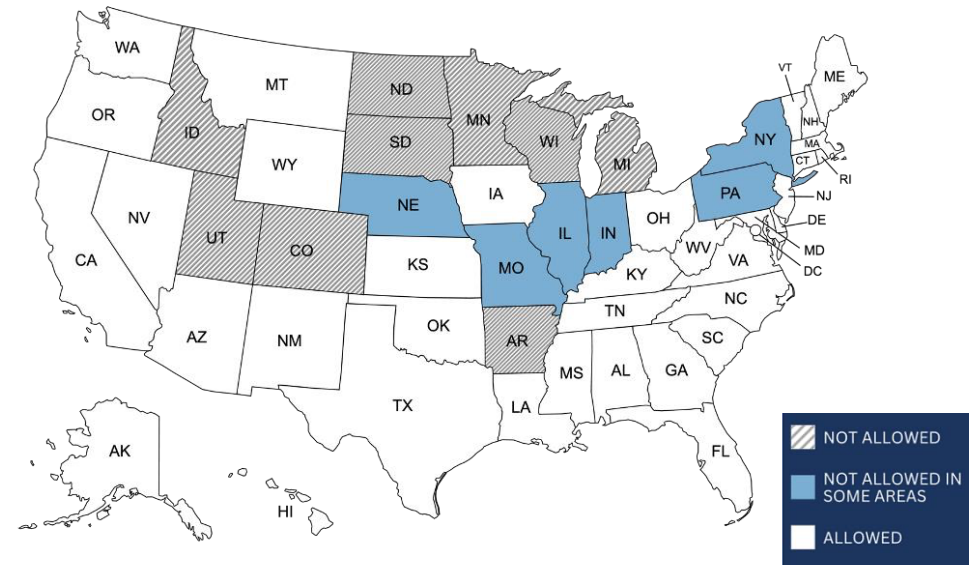

NEW PRODUCTS

WALL MOUNTED HOODS



SAVE on hanging hood costs and installation with our new wall mounted ZVS hoods!

NEW PRODUCTS

VENTLESS HOODS

Mobile Ventless

Available in 24", 39", and 48"



Ventless Exhaust Hood System Over Two Deck Electric Oven



Ventless Countertop Exhaust System



PRODUCT PORTFOLIO

WOOLGUARD

Reduce your hood cleanings up to 75%!

- 1. Increase System Efficiency** - With a cleaner hood system year-round, the entire exhaust system, hood, rooftop fans, HVAC and other equipment will run more efficiently.
- 2. Safety** – WoolGuard Hood Filters capture 98% of grease before it ever enters the exhaust system, reducing grease build-up and the risk of fires.
- 3. Cost Savings** - If your facility does quarterly hood cleanings, you likely only need to do them yearly. With 75% less hood cleanings, you won't need to use as much water and chemicals!

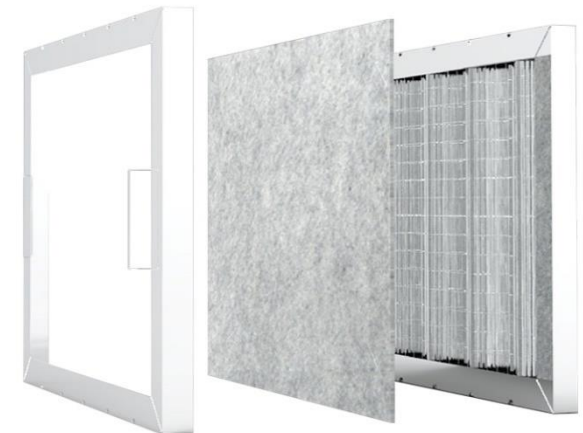
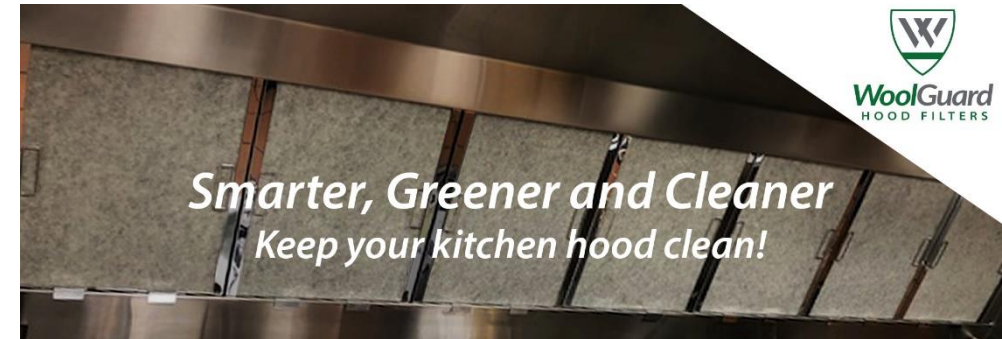

TRAINING

FS GENIUS

- Receive a login and train at your own pace with FS Genius
- 4 training courses available:
 - **Module 1** – Kitchen Ventilation Intellect
 - **Module 2** – What's needed from the rep to quote Z-Vent
 - **Module 3** – Types of hoods and applications
 - **Module 4** – Types of exhaust fans, supply air fan, MUA, and applications

Z-Ventilation - Module 1 - Kitchen Ventilatio... Z-VENTILATION KITCHEN VENTILATION INTELLECT > MORE

Completed. Let's continue.

Z-Ventilation - Module 1 - Kitchen Ventilatio... Z-VENTILATION KITCHEN VENTILATION INTELLECT > MORE

Completed. Let's continue.

Z-Ventilation - Module 1 - Kitchen Ventilatio... Z-VENTILATION KITCHEN VENTILATION INTELLECT > MORE

Completed. Let's continue.



ON TARGET INSTALLS

**Z-Vent is a one stop shop,
COMPLETE TURNKEY SOLUTION**

Z-Vent SOLUTIONS

CONTROL PANEL

LIGHTS FANS

